

**NEW**



# energy box



**Price list 2007**



### Type A

Length x Width x Height	3200 x 2430 x 2650	
Filling capacity	3,5 t	
Delivering system	Transport auger ST120	
Pellet store	Flexitank S2216 v.3.0	
Fire protection	<b>F60</b>	<b>F90</b>
	Checked by 	Checked by 
<b>1. ENERGY BOX</b>	<b>£ 5,735,-</b>	<b>£ 6,115,-</b>
<b>2. Pellet store - Flexitank S2216 v.3.0</b>		
		<b>£ 1,690,-</b>
<b>3. Delivering system - Transport auger ST120</b>		
		<b>£ 297,-</b>
<b>4. Boiler - PE 08</b>		
PE 10		<b>£ 4,234,-</b>
PE 15		<b>£ 4,884,-</b>
PE 20		<b>£ 5,016,-</b>
<b>5. Accessories</b>		
		<b>See page 7</b>

Total Ex-works price add lines 1,2,3,4 and 5. Prices for container include fitted S/S flue.  
 VAT & Delivery costs excluded, price on application. Delivery for all items 6-8 weeks.

The assembly of the type A according the following table:

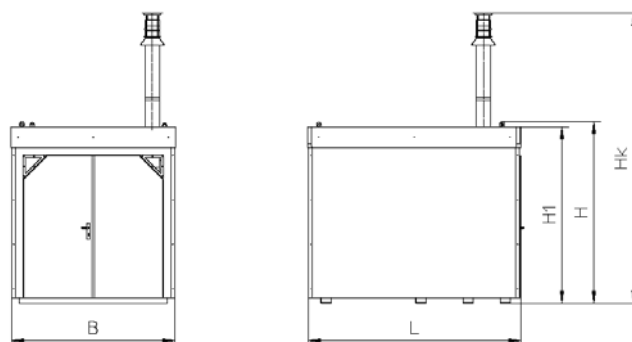
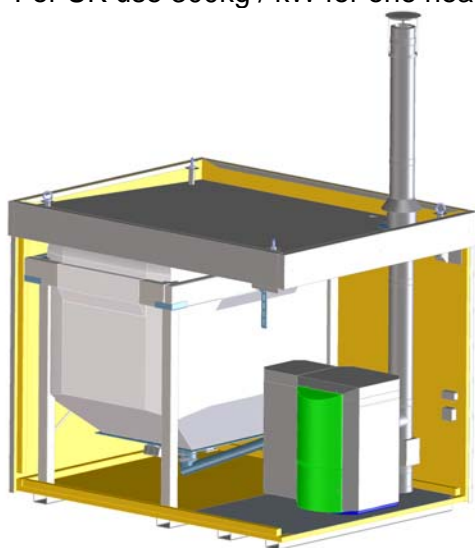

Boiler (kW)	8	12	15	20
Article no.	PE08	PE12	PE15	PE20
Consumption for one year (t)	3,2	4,8	6	8
fill / year (*)	1	2	2	2

(\*) Computed for a consumption of 400kg pellets / kW for one heating season  
 For UK use 300kg / kW for one heating season.



Length	L	mm	3200
Width	B	mm	2430
Height	H	mm	2650
Height without eyebolts	H1	mm	2580
Height inc. flue	Hk	mm	4500

### Type B

Length x Width x Height	4800 x 2430 x 2650	
Filling capacity	5,0 t	
Fire protection	<b>F60</b>	<b>F90</b>
	Checked by 	Checked by 
<b>1. ENERGY BOX</b>	<b>£ 6,045,-</b>	<b>£ 6,425,-</b>
<b>2. Pellet store - Flexitank S2822 v.3.0</b>		
		<b>£ 1.700, -</b>
<b>3. Delivering system - Transport auger ST220</b>		
		<b>£ 578,-</b>
<b>4. Boiler - PE 10</b>		
		<b>£ 4,884,-</b>
PE 15		<b>£ 5,016,-</b>
PE 20		<b>£ 5,147,-</b>
PE 25		<b>£ 5,750,-</b>
PE 32		<b>£ 5,881,-</b>
<b>5. Accessories</b>		
		<b>See page 7</b>

Total Ex-works price add lines 1,2,3,4 and 5. Prices for container include fitted S/S flue.  
VAT & Delivery costs excluded, price on application. Delivery for all items 6-8 weeks.

The assembly of the type B according the following table:

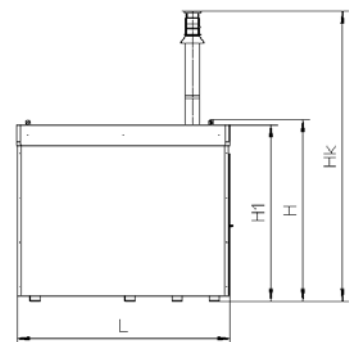
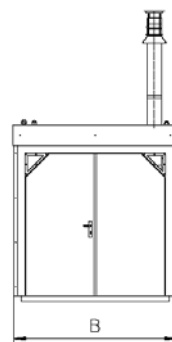
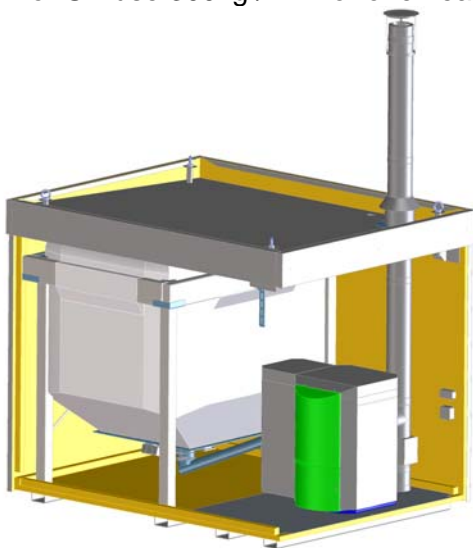

Boiler (kW)	12	15	20	24	28
Article no.	PE 12	PE 15	PE 20	PE 24	PE 28
Consumption for one year (t)	4,8	6	8	9,6	11,2
fill / year (*)	1	2	2	2	3

(\*) Computed for a consumption of 400kg pellets / kW for one heating season  
For UK use 300kg / kW for one heating season.



Length	L	mm	4800
Width	B	mm	2430
Height	H	mm	2650
Height without eyebolts	H1	mm	2580
Height inc. flue	Hk	mm	4500

### Type C

Length x Width x Height	6200 x 2430 x 2650	
Pellet store	Storage room with sloping floor	
Delivering system	Vacuum suction system	
Filling capacity	9,5 t	
Fire protection	<b>F60</b>	<b>F90</b>
	Checked by 	Checked by 
<b>1. ENERGY BOX</b>	<b>£ 8,735,-</b>	<b>£ 9,115,-</b>
<b>2. Pellet transport auger - RS-14</b>	<b>£ 805, -</b>	
<b>3. Boiler - PES 10</b>	<b>£ 5,570,-</b>	
<b>PES 15</b>	<b>£ 5,701,-</b>	
<b>PES 20</b>	<b>£ 5,832,-</b>	
<b>PES 25</b>	<b>£ 6,522,-</b>	
<b>PES 32</b>	<b>£ 6,654,-</b>	
<b>PES 36</b>	<b>£ 8,899,-</b>	
<b>PES 48</b>	<b>£ 9,215,-</b>	
<b>PES 56</b>	<b>£ 9,425,-</b>	
<b>4. Accessories</b>	<b>See page 7</b>	

Total Ex-works price add lines 1,2,3 and 4. Prices for container include fitted S/S flue.  
 VAT & Delivery costs excluded, price on application. Delivery for all items 6-8 weeks.

The assembly of the type C according the following table:

Boiler (kW)	15	20	24	28	36	48	56
Article no.	PES 15	PES 20	PES 24	PES 28	PES 36	PES 48	PES 56
Consumption for one year (t)	6	8	9,6	11,2	14,4	19,2	22,4
fill / year (*)	1	1	1	2	2	2	3

(\*) Computed for a consumption of 400kg pellets / kW for one heating season  
 For UK use 300kg / kW for one heating season.

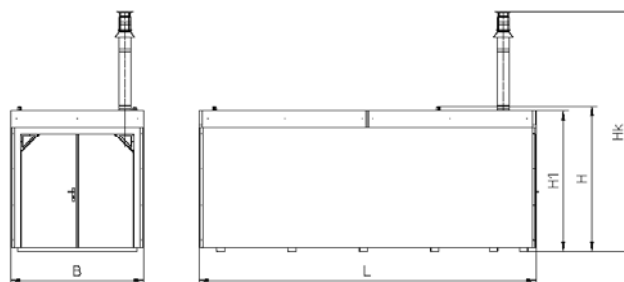
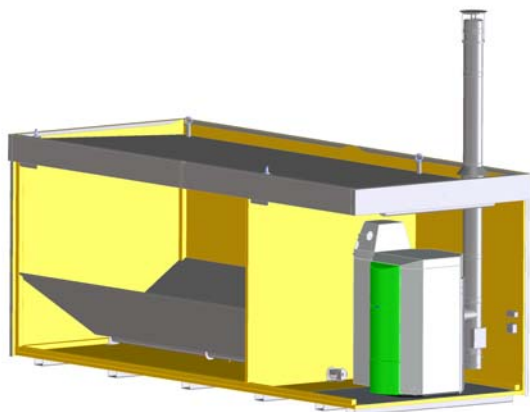

Length	L	mm	6200
Width	B	mm	2430
Height	H	mm	2650
Height without eyebolts	H1	mm	2580
Height inc. flue	Hk	mm	4500

### Type D

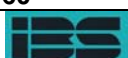
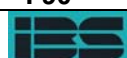
Length x Width x Height	10200 x 2430 x 2650	
Pellet store	Storage room with sloping floor	
Delivering system	Vacuum suction system	
Filling capacity	15,0 t	
Tandem Boiler		
Fire protection	<b>F60</b>	<b>F90</b>
	Checked by 	Checked by 
<b>1. ENERGY BOX</b>	<b>£ 14,175,-</b>	<b>£ 14,575,-</b>
<b>2. Pellet transport auger - 2 x RS-13</b>		
		<b>£ 1.468, -</b>
<b>3. Boiler - PETS 72</b>		
		<b>£ 16,018,-</b>
	<b>PETS 96</b>	<b>£ 16,586,-</b>
	<b>PETS 112</b>	<b>£ 16,964,-</b>
<b>4. Accessories</b>		
		<b>See page 7</b>

Total Ex-works price add lines 1,2,3 and 4. Prices for container include fitted S/S flue.  
 VAT & Delivery costs excluded, price on application. Delivery for all items 6-8 weeks.

The assembly of the type D according the following table:

Boiler (kW)	2x36 72	2x48 96	2x56 112
Article no.	PETS 72	PETS 96	PETS 112
Consumption for one year (t)	28,8	38,4	44,8
Fill / year (*)	2	3	3

(\*) Computed for a consumption of 400kg pellets / kW for one heating season  
 For UK use 300kg / kW for one heating season.

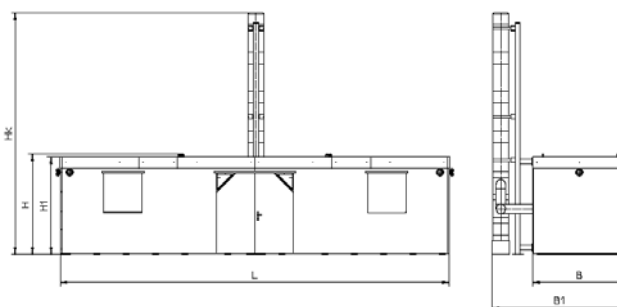
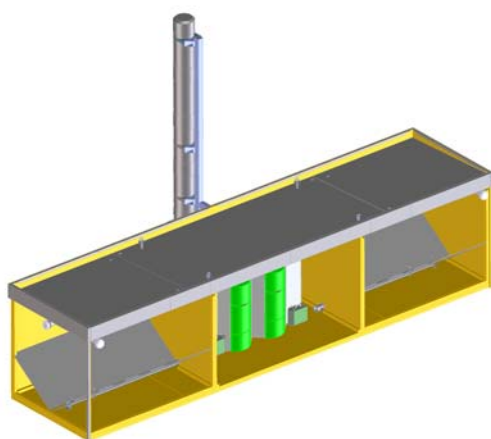

Length	L	mm	10200
Width	B	mm	2430
Width with flue	B1	Mm	3500
Height	H	mm	2650
Height without eyebolts	H1	mm	2580
Height inc. flue	Hk	mm	6300

### Type E

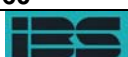
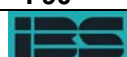
Length x Width x Height	12200 x 2430 x 2650	
Pellet store	Storage room with sloping floor	
Delivering system	Vacuum suction system	
Filling capacity	14,0 t	
Fire protection	<b>F60</b>	<b>F90</b>
	Checked by 	Checked by 
<b>1. ENERGY BOX</b>	<b>£ 19,073,-</b>	<b>£ 19,833,-</b>
<b>2. Pellet transport auger - 4 x RS-13</b>	<b>£ 2.936, -</b>	
<b>3. Boiler - 4 x PES 36</b>	<b>£ 35,596,-</b>	
<b>4 x PES 56</b>	<b>£ 37,700,-</b>	
<b>4. Accessories</b>	<b>See page 7</b>	

Total Ex-works price add lines 1,2,3 and 4. Prices for container include fitted S/S flue. VAT & Delivery costs excluded, price on application. Delivery for all items 6-8 weeks.

The assembly of the type E according the following table:

Boiler (kW)	4x36 144	4x56 224
Article no.	4x PES 36	4x PES 56
Consumption for one year (t)	57,6	89,6
fill / year (*)	4	6

(\*) Computed for a consumption of 400kg pellets / kW for one heating season  
 For UK use 300kg / kW for one heating season.

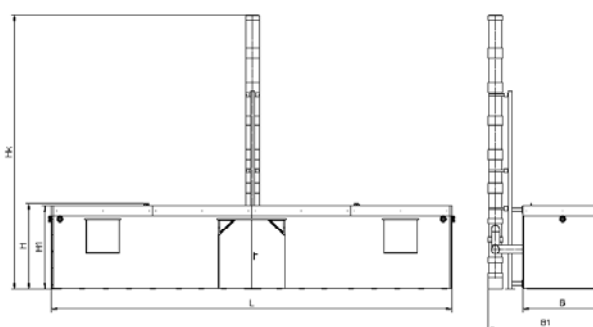
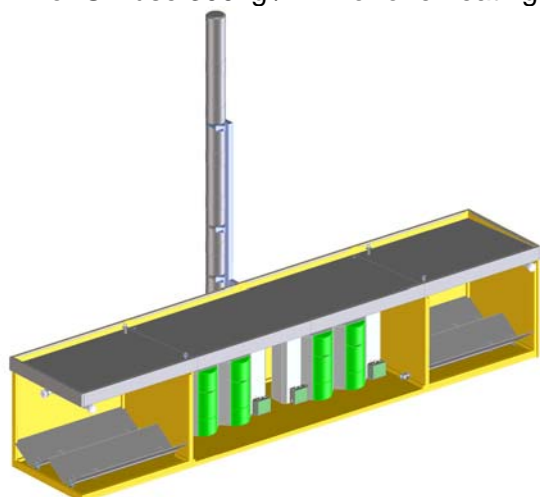

Length	L	mm	12200
Width	B	mm	2430
Width with flue	B1	Mm	3500
Height	H	mm	2650
Height without eyebolts	H1	mm	2580
Height inc. flue	Hk	mm	8300

### Accessories for type A and B

1	No.	EPM2940	System controller for 1 no. mixing circuits 1 no. DHW		<b>£ 320,-</b>
			<b>or</b>		
1	No.	EPM2945	System controller for 2 no. mixing circuits 1 no. DHW		<b>£ 547,-</b>
			<b>Plus</b>		
1	No.	S 106 HK	Filler nozzle		<b>£ 85,-</b>

### Accessories for type C

1	No.	EPM2940	System controller for 1 no. Mixixg circuits 1 no. DHW		<b>£ 320,-</b>
			<b>or</b>		
1	No.	EPM2945	System controller for 2 no. mixing circuits 1 no. DHW		<b>£ 547,-</b>
			<b>Plus add</b>		
1	No.	ZBSM	Fire hose		<b>£ 44,-</b>
1	No.	12104715	Vacuum hose 15m.		<b>£ 75,-</b>
1	No.		Clamps fixings and support shells for vacuum hose	P.C. sum	<b>£ 100,-</b>
1	No.	ZK-G050	Straight set pipefittings		<b>£ 99,-</b>
1	No.	ZPM	Deflecting mat		<b>£ 31,-</b>

### Accessories for type D

1	No.	EPM2940	System controller for 1 no. Mixixg circuits 1 no. DHW		<b>£ 320,-</b>
			<b>or</b>		
1	No.	EPM2945	System controller for 2 no. mixing circuits 1 no. DHW		<b>£ 547,-</b>
			<b>Plus add</b>		
2	No.	ZBSM	Fire hose	£ 44,-	<b>£ 88,-</b>
2	No.	12104715	Vacuum hose 15m.	£ 75,-	<b>£ 150,-</b>
2	No.		Clamps fixings and support shells for vacuum hose	£ 100,-	<b>£ 200,-</b>
2	No.	ZK-G050	Straight set pipefittings	£ 99,-	<b>£ 198,-</b>
2	No.	ZPM	Deflecting mat	£ 31,-	<b>£ 62,-</b>

### Accessories for type E

1	No.	EPM2940	System controller for 1 no. Mixixg circuits 1 no. DHW		<b>£ 320,-</b>
			<b>or</b>		
1	No.	EPM2945	System controller for 2 no. mixing circuits 1 no. DHW		<b>£ 547,-</b>
			<b>Plus add</b>		
4	No.	ZBSM	Fire hose	£ 44,-	<b>£ 176,-</b>
4	No.	12104715	Vacuum hose 15m.	£ 75,-	<b>£ 300,-</b>
4	No.		Clamps fixings and support shells for vacuum hose	£ 100,-	<b>£ 400,-</b>
4	No.	ZK-G050	Straight set pipefittings	£ 99,-	<b>£ 396,-</b>
4	No.	ZPM	Deflecting mat	£ 31,-	<b>£ 124,-</b>